

Customer Code:

# DATASHEET

DAPU P/N: CM66K-D129-10.00MHz-C

Customer P/N: \_\_\_\_\_

DAPU			Customer Approval
Drew	Audited	Approved	Stamp, please! Thanks!
Date: 2025.03.03			

## Guangdong Dapu Telecom Technology Co.,Ltd

Building 5, No.24, Industrial East Road, Songshanhu Park, Dongguan, Guangdong, P.R. China

TEL: 0086-0769-88010888 FAX: 0086-0769-81800098





## Table of Content

1. GENERAL DESCRIPTION.....	4
2. PIN DEFINITION.....	5
3. ELECTRICAL PARAMETERS .....	5
4. PERFORMANCE.....	6
5. UART.....	7
6. CONTROL AND STATUS PINS.....	9
7. ENVIRONMENTAL CONDITIONS.....	9
8. TYPICAL APPLICATION .....	10
9. MECHANICAL STRUCTURE (MM) .....	11
10. WAVE SOLDERING CURVE(ROHS).....	12
11. PACKAGE (MM) .....	12



## 1. General Description

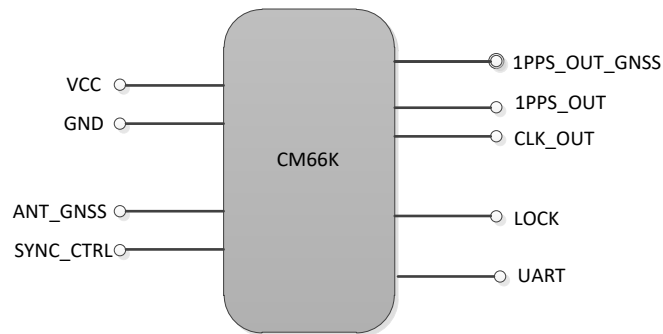

**Figure 1 CM66K**

Figure 1 is the basic diagram of CM66K. CM66K is a high-performance clock module designed to provide precise frequency and phase synchronizing with internal time reference for telecom and other applications.

### Key features:

- **Reference:** GNSS receiver
- **Temperature Stability:**  $\pm 0.2\text{ppb}$ ;
- **Holdover:**  $\pm 1.5\mu\text{s}/24\text{h}$  @  $\Delta T = \pm 5^\circ\text{C}$ ;
- **Clocks Output:** 2\*1PPS output and 1\*10MHz output;
- **Serial Interface:** 1\*UART for TOD and management;
- **Mechanical Size:** 60mm\*60mm\*13mm.



## 2. Pin Definition

**Table 1 Pin Definition**

Pin group	Pin#	Pin Name	Type	Description
Supply Voltage	4, 9, 11, 13	GND	GND	Ground
	12	VCC	PWR	Power Supply
Control and Status Pins	8	SYNC_CT RL	I	Synchronizing Procedure Control
	5	LOCK	O	Lock Status
UART	6	RXD0	I	Asynchronous Serial Data Output/Input. 9600-N-8-1
	7	TXD0	O	
GNSS	10	1PPS_OUT	O	1PPS Output from the internal GNSS receiver.
	SMA-KE	ANT	I	GNSS ANT signal input
Output Clocks	3	1PPS_OUT	O	1PPS Output
	2	CLK_OUT	O	10.00MHz Output
Reserve	1, 14	NC		Not connected.

## 3. Electrical Parameters

**Table 2 Electrical Parameters**

Parameter	Symbol	Minimum	Typical	Maximum	Units
<b>LVC MOS Input</b>					
High Level Input Voltage	V <sub>IH</sub>	2.7			V
Low Level Input Voltage	V <sub>IL</sub>			0.4	V
<b>LVC MOS Output</b>					
High Level Output Voltage	V <sub>OH</sub>	2.7			V
Low Level Output Voltage	V <sub>OL</sub>			0.4	V



## 4. Performance

**Table 3 Performance**

Item	Parameter	Minimum	Typical	Maximum	Units	Test Condition	
Internal Receiver Characteristics	Number of Channels			50			
	Frequency Band	BD2 B1(1561.098MHz) L1 (1575.42 MHz)					
	Tracking Code					C/A Code	
	Tracking Capability			12		12 Satellites	
	Sensitivity			-159		dBm	Tracking & Navigation
			-144		dBm	Acquisition	
Clock Output	Nominal Frequency	10.00			MHz	Synchronizing with GNSS1PPS output.	
	Duty Cycle	45	50	55	%	Load 15pF	
	Frequency vs. Temperature	-0.2		+0.2	$\times 10^{-9}$	V <sub>cc</sub> =5.0V; O <sub>load</sub> =15pF; T <sub>A</sub> varies from -40°C to 80°C, temperature slope less than °Cper minute.	
	Accuracy	-1		+1	$\times 10^{-12}$	24 hours average value when locked to 1PPS.	
	Short-term Stability	-0.02		+0.02	$\times 10^{-9}$	V <sub>cc</sub> =5.0V; T <sub>A</sub> =25°C; 1s; no EMI\EMC or other interference.	
	Daily Aging	-0.2		+0.2	$\times 10^{-9}$	V <sub>cc</sub> =5.0V; T <sub>A</sub> =25°C. FREE RUN condition and after 30 days of operation.	
	Yearly Aging	-0.01		+0.01	$\times 10^{-6}$		
	Phase Noise			-118	-113	dBc/Hz	10Hz
				-138	-133		100Hz
				-148	-143		1KHz
			-150	-145	10KHz		
			-150	-145	100KHz		
			-150	-150	1MHz		



1 PPS Output	Pulse Width		100		ms	
	Accuracy	-20		+20	ns	Synchronizing with 1PPS reference. Mean is 0, and standard deviation is 20ns. After locking, monitor 24 hours.
	24 hours holdover	-1.5		+1.5	μs	ΔT=±5°C, 24 hours holdover after turn on 7days and GPS lock 3days. Temperature variable speed less than 1°Cper minute
Supply Voltage	Supply Voltage	4.75	5.0	5.25	V	
	Warm Up Current			2000	mA	During Warm-up
	Steady Current			1000	mA	During steady state operation @25°C
	AC Ripple			50	mV pk-pk	10Hz to 1MHz



## 5.UART

UART interfaces are used for management and TOD, which has a fixed baud rate (9600) using 1 stop bit and no parity. It is a LVTTTL-compatible port and needs an external translator to work with other signal types (such as RS-232C or RS-485).

TOD messages support inputting \$GxRMC(\$GPRMC/\$GBRMC/\$GLRMC/\$GARMC/\$GNRMC) through a serial port; When there is no receiver signal during the startup phase, the time can be written and timed through the serial port. The time it takes for the receiver to use it after normal satellite search.

Example:

```
$GPRMC,083559.00,A,4717.11437,N,00833.91522,E,0.004,77.52,091202,,,A,V*57
```

Field No.	Name	Unit	Format	Example	Description
0	xxRMC	-	string	\$GPRMC	RMC Message ID (xx = current Talker ID, see <a href="#">NMEA Talker IDs table</a> )
1	time	-	hhmmss.ss	083559.00	UTC time, see <a href="#">note on UTC representation</a>
2	status	-	character	A	Data validity status, see <a href="#">position fix flags description</a>
3	lat	-	ddmm. mmmm	4717.11437	Latitude (degrees & minutes), see <a href="#">format description</a>
4	NS	-	character	N	North/South indicator
5	lon	-	dddmm. mmmm	00833.91522	Longitude (degrees & minutes), see <a href="#">format description</a>
6	EW	-	character	E	East/West indicator
7	spd	knots	numeric	0.004	Speed over ground
8	cog	degrees	numeric	77.52	Course over ground

Field No.	Name	Unit	Format	Example	Description
9	date	-	ddmmyy	091202	Date in day, month, year format, see <a href="#">note on UTC representation</a>
10	mv	degrees	numeric	-	Magnetic variation value. Only supported in ADR 4.10 and later
11	mvEW	-	character	-	Magnetic variation E/W indicator. Only supported in ADR 4.10 and later
12	posMode	-	character	A	Mode Indicator, see <a href="#">position fix flags description</a> (only available in NMEA 2.3 and later)
13	navStatus	-	character	V	Navigational status indicator: V (Equipment is not providing navigational status information, fixed field, only available in NMEA 4.10 and later)
14	cs	-	hexadecimal	*57	Checksum
15	<CR><LF>	-	character	-	Carriage return and line feed





## 6. Control and Status Pins

CM66K is a clock module which synchronizes the local clock to reference such as 1 PPS retrieving from GNSS. CM66K will work normally performing synchronizing algorithm when the SYNC\_CTRL pin is driven high. It also could be force to work in free-run or holdover status when the SYNC\_CTRL pin is driven low.

The LOCK pin indicates the lock status of CM66K. High level indicates the module is locked to GNSS reference. When the module never is locked to reference after power up, the status of module is free-run, the LOCK pin outputs low. When the GNSS signal is lost, the status of module is holdover, the LOCK pin also output low.

## 7. Environmental Conditions

**Table 4 Environmental Conditions**

Parameter	Conditions	
Operable Temperature	-40°C to 85°C	
Storage Temperature	-55°C to 105°C	
Storage Humidity	30%~80%	
ESD Level	Human Body Model, class2: 2000V to 4000V; ANSI/ESDA/JEDEC JS-001-2010.	
	Machine Model, class B: 200V to 400V; JEDEC JESD22-A115C.	
Moisture Sensitivity Level	Not Humidity Sensitive.	
Vibration	Test Condition: 0.75mm ;acceleration:10g;10Hz~500Hz, one cycle per 30 min, test 2 hour. (3 times for each 3 directions X , Y , Z), IEC 68-2-06 Test Fc.	
Shock	50g; 11ms; half sine wave (3 times for each 3 directions X,Y,Z),IEC 68-2-27 Test Ea/Severity 50A.	
Relative Humidity	20%~70%	Full Package Storage
Temperature	-10°C~35°C	



## 8. Typical Application

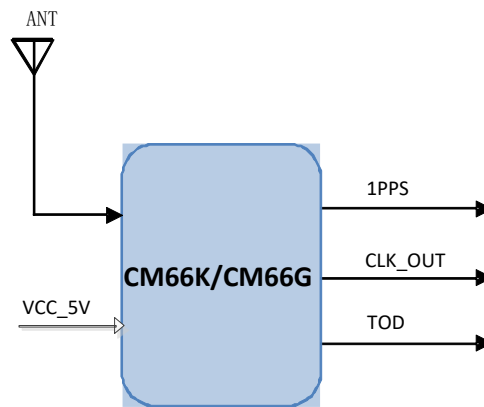

**Figure 2**Typical application

GNSS Receiver is embedded in CM66K.



## 9. Mechanical Structure (mm)

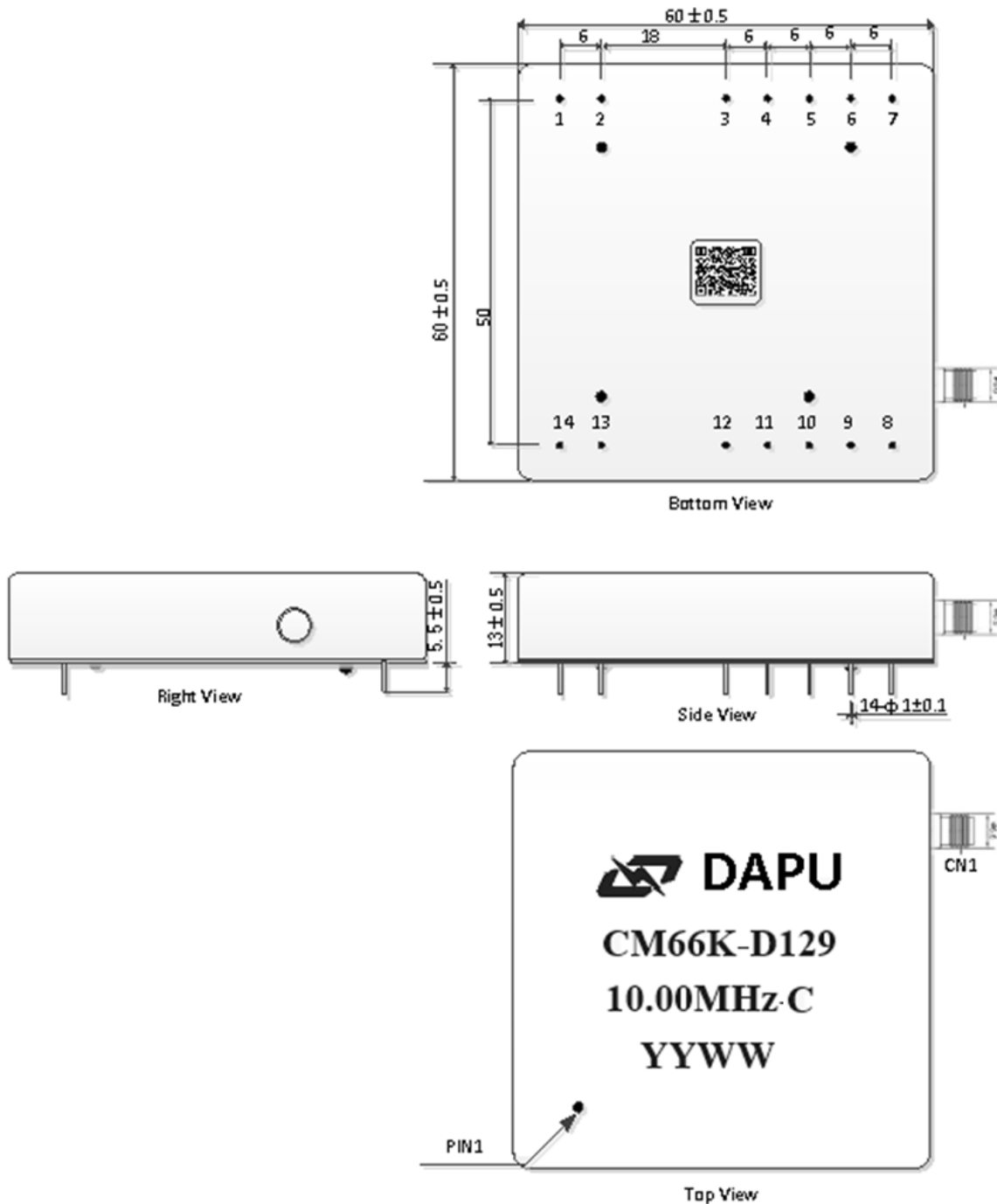

Figure 3 Mechanical structure

**Note1:** Tolerance  $\pm 0.2$ mm without mark.

**Note2:** YY represents Year.

WW represents Week.

**Note3:** Referential Weight  $82 \pm 10$ g



### 10.Wave Soldering Curve(RoHS)

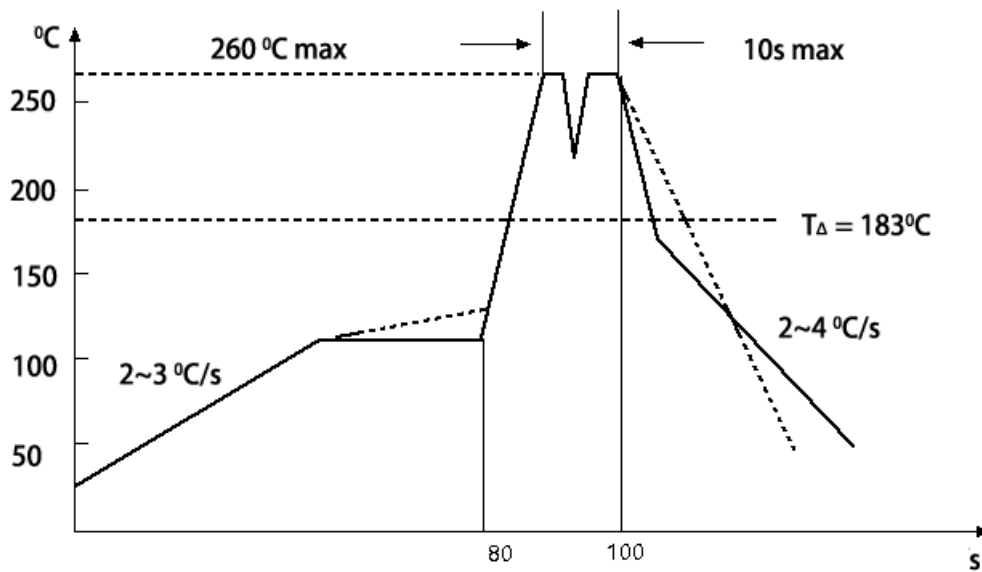

Figure 4 Wave soldering curve

### 11.Package (mm)

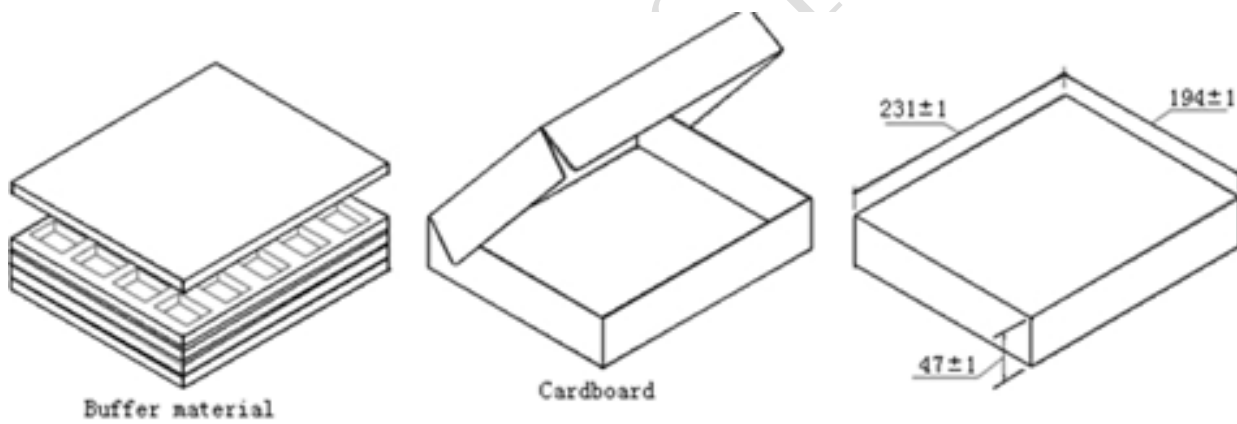

Figure 5 Package