

Customer Code : _____

DATASHEET

DAPU P/N : **O11L-L325-20.00MHz**

Customer P/N: _____

DAPU			Customer Approval
Drew	Audited	Approved	Stamp, please! Thanks!
Date: 2025.02.14			

Guangdong Dapu Telecom Technology Co.,Ltd

Building 5, No.24, Industrial East Road, Songshanhu Park, Dongguan, Guangdong, P.R. China

TEL: 0086-0769-88010888 FAX: 0086-0769-81800098



1. Electrical Parameters

MODEL: O11L-L325-20.00MHz						
Item	Description	Parameters			Unit	Test Condition
		Min.	Typ.	Max.		
Output	Frequency	20.00			MHz	
	Output Waveform	HCMOS				
	Output Low Voltage			0.4	V	$V_{cc}=5.0V, O_{load}=10K\Omega// 10pF$
	Output High Voltage	3.8			V	$V_{cc}=5.0V, O_{load}=10K\Omega// 10pF$
	Duty Cycle	45	50	55	%	@50%
	Load	10K Ω // 10pF			pF	
Frequency Stabilities	Frequency Tolerance vs. Operating Temperature Range	-0.05		+0.05	$\times 10^{-6}$	T_A varied from -40 $^{\circ}C$ to 85 $^{\circ}C$, measurement referenced to frequency observed with $T_A=25^{\circ}C, V_{cc}=5.0V, V_c=2.1V, O_{load}=10K\Omega// 10pF$, temperature variable speed less than 2 $^{\circ}C$ per minute.
	Initial Frequency Tolerance	-0.2		+0.2	$\times 10^{-6}$	Measurement referenced to frequency observed with $T_A=25^{\circ}C, V_{cc}=5.0V, V_c=2.1V$ and after 15 minutes of operation, within 30 days after ex-works.
	Frequency Tolerance vs. supply voltage	-5		+5	$\times 10^{-9}$	measurement referenced to frequency observed $T_A=25^{\circ}C, V_{cc}$ varied from 4.75V to 5.25V, $V_c=2.1V, O_{load}=10K\Omega// 10pF$.
	Frequency Tolerance vs. Load	-5		+5	$\times 10^{-9}$	5% Load Change Measurement referenced to frequency observed with $T_A=25^{\circ}C, V_{cc}=5.0V, V_c=2.1V, O_{load}=10K\Omega// 10pF$.
	Aging Tolerance per day	-1		+1	$\times 10^{-9}$	V_{cc}, V_c, T_A constant Measurement referenced to frequency observed with $T_A=25^{\circ}C,$
	Aging Tolerance 1Year	-0.1		+0.1	$\times 10^{-6}$	$V_{cc}=5.0V, V_c=2.1V, O_{load}=10K\Omega// 10pF$ and after 30 days of operation.
Power Supply	Supply Voltage	4.75	5	5.25	V	
	Steady Consumption		50	85	mA	@25 $^{\circ}C$
	Warm up current			260	mA	
	Vref Out	4		4.3	V	
	Warm-Up Time		60	90	s	@25 $^{\circ}C, Df/f=0.1 \times 10^{-6}$.



Voltage Control Characteristics	Frequency Tuning Range			-1	$\times 10^{-6}$	$V_c=0V$. measurement referenced to $V_c=2.1V$.
		-0.2		+0.2	$\times 10^{-6}$	$V_c=2.1V$. measurement referenced to exactly 20.00MHz.
		+1			$\times 10^{-6}$	$V_c=4.2V$. measurement referenced to $V_c=2.1V$.
	Linearity			10	%	
	Slope	Positive				
	Input Impedance		100		K Ω	
	Input BW		160		Hz	-3dB
Output resistance of Vref		91		Ω		
Phase Noise	Phase Noise (Static)			-70	dBc/Hz	1Hz
				-115		10Hz
				-143		100Hz
				-153		1KHz
				-155		10KHz
				-155		100KHz
Environmental Conditions	Operable Temperature	-40		+85	$^{\circ}C$	
	Storage Temperature	-60		+90	$^{\circ}C$	
	ESD Level	Human Body Model, class2: 2000V to 4000V; ANSI/ESDA/JEDEC JS-001-2010.				
		Machine Model, class B: 200V to 400V; JEDEC JESD22-A115C.				
	Moisture Sensitivity Level	Not humidity sensitive.				
	Vibration	Test Condition: 0.75mm ;acceleration:10g;10Hz~500Hz, one cycle per 30 min, test 2 hour. (3 times for each 3 directions X , Y , Z), IEC 68-2-06 Test Fc.				
Shock	50g; 11ms; half sine wave (3 times for each 3 directions X, Y, Z), IEC 68-2-27 Test Ea/Severity 50A.					
Full Package Storage	Relative humidity (%)	20%~70%				
	Temperature ($^{\circ}C$)	-10~35 $^{\circ}C$				



2. Mechanical Structure (mm)

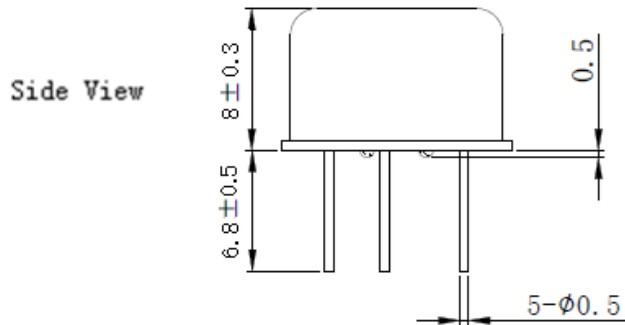
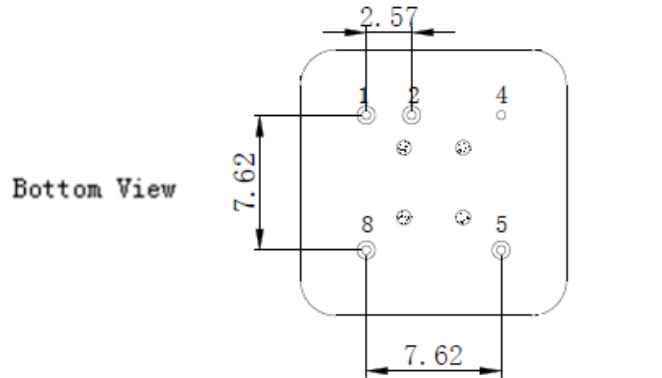

PIN FUNCTION

PIN	NOTATION	FUNCTION
1	VC	Control Voltage
2	VREF	Reference Voltage
4	GND	GND
5	OUTPUT	RF Output
8	VCC	Supply Voltage

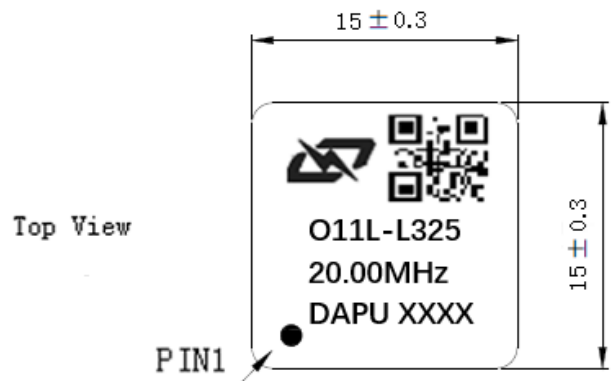

Note1: Tolerance ± 0.2mm without mark

Note2: The first two xx representative: year
The last two xx representative: week

Note3: Referential weight 5.0g



3. Test Circuit

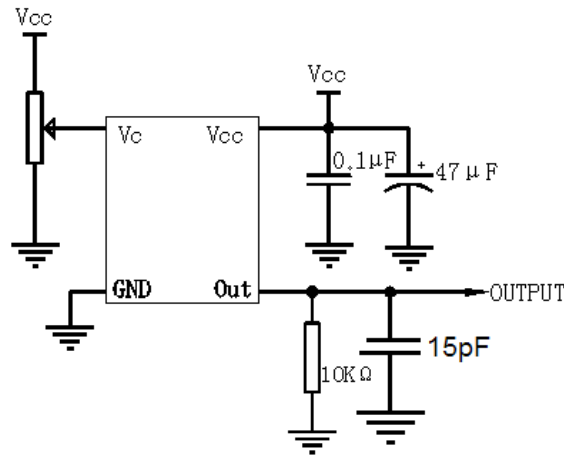

4. Reflow Soldering Curve (RoHS)

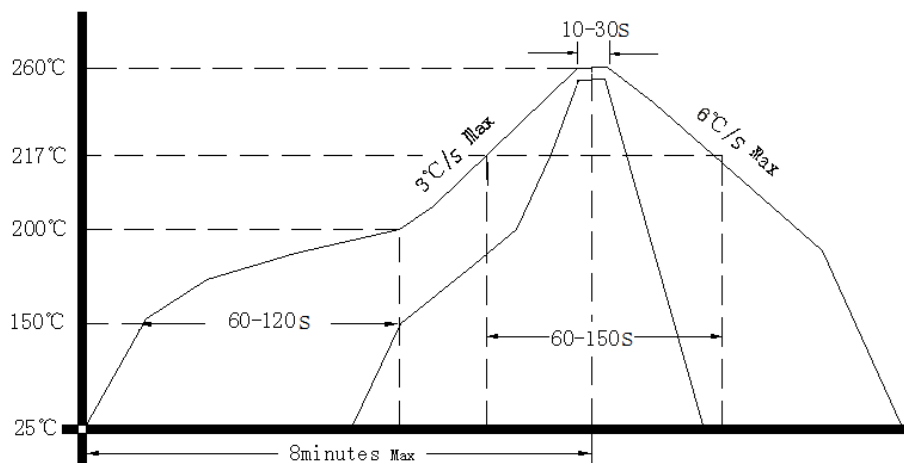

5. Package(mm)

