

Customer Code: _____

DATASHEET

DAPU P/N: T2016G-B5A9CK-26.00MHz-D0

DAPU			Customer Approval
Drew	Audited	Approved	
Jieshu ZHENG	Jianhua LIN	Gangtao FENG	
Date:	2025/2/6		
			Stamp, please! Thanks!

Guangdong Dapu Telecom Technology Co.,Ltd

Bldg 5, SSL Modern Enterprise Accelerator Zone, Dongguan City, Guangdong Province, PRC China
TEL: 0086-0769-88010888 FAX: 0086-0769-81800098

Table of amendment

Version	Revision contents	Prepared by	Revised date
1.0	The first issued	Jieshu ZHENG	2025/2/6

1、Electrical Parameter

MODEL:		T2016G-B5A9CK-26.00MHz-D0				
No.	Description	Parameters			Units	Test Condition
		Min.	Typ.	Max.		
Output	Frequency	26.000			MHz	
	Output Waveform	Clipped Sine Wave			-	
	Vp-p	0.8			V	
	Spurious Suppression			-8	dBc	
	Load	10KΩ//10pF				
Frequency Stabilities	Frequency Tolerance	-1.5		1.5	×10 ⁻⁶	@25±2°C, 2H, after 2 times reflow soldering, base on nominal frequency.
	vs. Temperature	-0.5		0.5	×10 ⁻⁶	T _A varied from -40°C to 85°C, measurement referenced to frequency observed with f _{ref} =(f _{max} +f _{min})/2, V _{CC} =3.3V, O _{load} =10KΩ//10pF, temperature variable speed less than 2°C per minute.
	vs. Supply Voltage	-0.1		0.1	×10 ⁻⁶	measurement referenced to frequency observed T _A =25°C, V _{CC} =3.3V±10%, and O _{Load} =10KΩ//10pF.
	vs. Load	-0.1		0.1	×10 ⁻⁶	10% load change measurement referenced to frequency observed with T _A =25°C, V _{CC} =3.3V, and O _{Load} =10KΩ//10pF.
	Aging Tolerance 1 Year	-1		1	×10 ⁻⁶	T _A =25°C, V _{CC} =3.3V, and after 1h of operation.
	Clock Drift	-15		15	ppb/s	-40~85°C, 0.17°C/s
	Frequency Slope	-0.1		0.1	ppm/°C	T _A varied from -40°C to 85°C
Power Supply	Current consumption			2	mA	@25°C, V _{CC} =3.3V, O _{Load} =10KΩ//10pF.
	Start up Time			2	ms	More than 90% of final output voltage
	Supply Voltage	1.71	3.30	3.63	V	
SSB Phase Noise	Phase Noise@25±2°C			-50	dBc/Hz	1Hz
				-83		10Hz
				-113		100Hz
				-138		1KHz
				-145		10KHz
				-153		100KHz
				-155		1MHz

Environmental Conditions	Operable Temperature	-40		85	°C	
	Storage Temperature	-55		105	°C	
	ESD Level	Human Body Model, class 2: 2000V to 4000V; ANSI/ESDA/JEDEC JS-001-2010.				
		Machine Model, class B: 200V; JEDEC JESD22-A115C.				
	Moisture Sensitivity Level	Level 3.				
	Vibration	Test Condition: 0.75mm ;acceleration:10g;10Hz~2000Hz, one cycle per 30 min, test 2 hour. (3 times for each 3 directions X ,Y, Z) .IEC 68-2-06 Test Fc.				
Shock	100g; 6ms; half sine wave (3 times for each 3 direction s X ,Y, Z), IEC 68-2-27 Test Ea/Severity 50A.					
Full Package Storage	Relative humidity (%)	20%~70%				
	Temperature (°C)	-10~35°C				

2、 Test Circuit

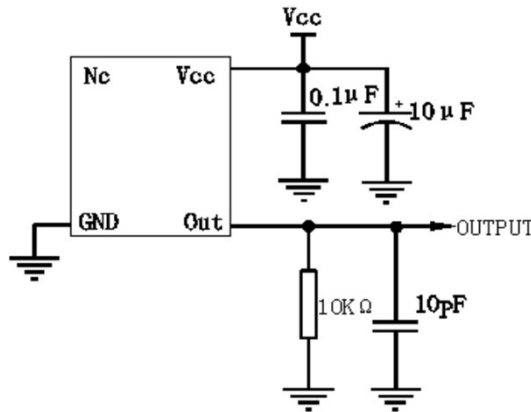

3、 Reflow Soldering Curve (RoHS)

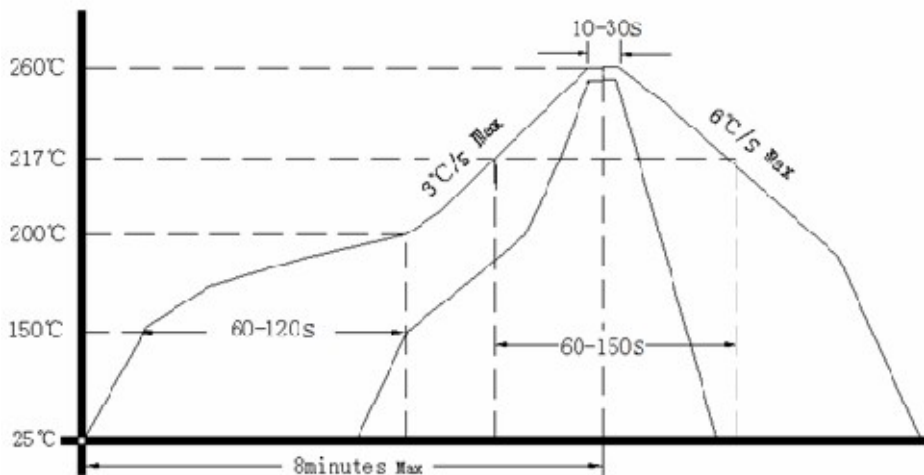

4、 Mechanical Structure(mm)

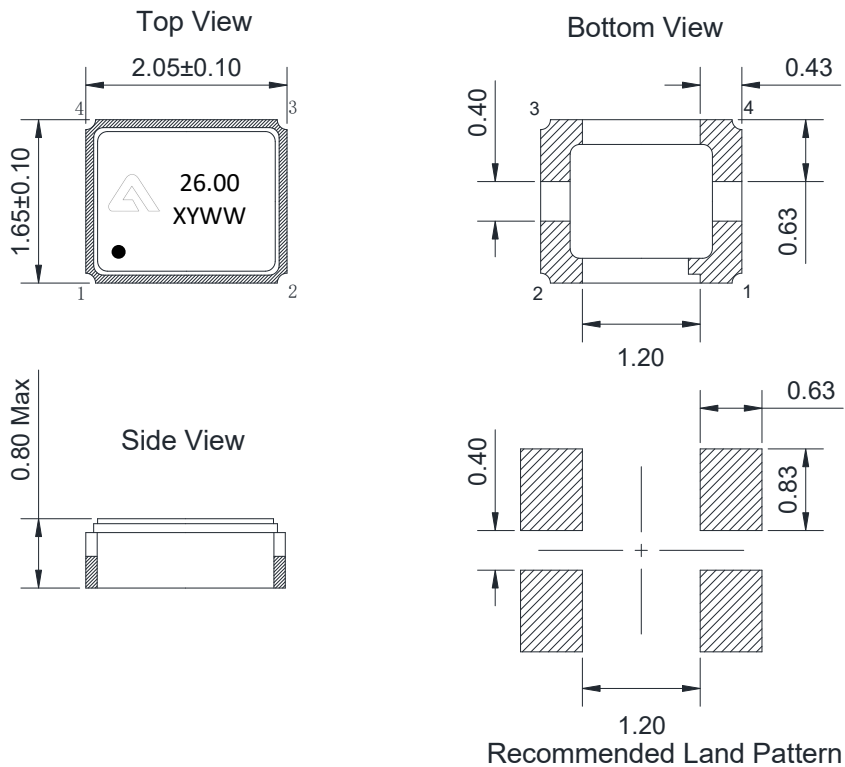

Note: X representative internal code ,Y representative year, WW representative week

PIN NAME	CONNECTION
PIN1	NC
PIN2	GND
PIN3	F _{OUT}
PIN4	V _{CC}