

Travelling Merchant: _____

DATASHEET

Standard: **O75A-S319-10.00MHz-G215**

P/N: _____

Plot			The Label
Drew	Audited	Approved	Stamp, please! Thanks!
Date: 2024.10.29			

Guangdong Dapu Telecom Technology Co.,Ltd

Building 5, No.24, Industrial East Road, Songshanhu Park, Dongguan, Guangdong, P.R. China

TEL: 0086-0769-88010888 FAX: 0086-0769-81800098



Table of amendment

Version	Revision contents	Prepared by	Revised date
1.0	The first issued	<i>Amway</i>	2024.10.29

DAPU

Confidential



1. Electrical Parameters

MODEL: O75A-S319-10.00MHZ-G215						
Item	Description	Parameters			Unit	Test Condition
		Min.	Typ.	Max.		
Output	Frequency	10.00			MHz	
	Output Waveform	HCMOS				
	Output Low Voltage			0.4	V	$V_{cc}=3.3V, O_{load}=15\text{ pF}$
	Output High Voltage	2.4			V	$V_{cc}=3.3V, O_{load}=15\text{ pF}$
	Duty Cycle	45		55	%	@50%
	Rise / Fall Time			6	ns	10%~90%
	Load	15			pF	
Frequency Stabilities	Frequency Tolerance vs. Operating Temperature Range	-0.02		+0.02	$\times 10^{-6}$	T_A varied from -40°C to 105°C , measurement referenced to frequency observed with $f_{ref}=(f_{max}+f_{min})/2, V_{cc}=3.3V, O_{load}=15\text{ pF}$, temperature variable speed less than 2°C per minute.
	Initial Frequency Tolerance	-1.5		+1.5	$\times 10^{-6}$	Measurement referenced to frequency observed with $T_A=25^{\circ}\text{C}, V_{cc}=3.3V$ within 30 days after ex-works.
	Frequency Tolerance vs. Supply Voltage	-5		+5	$\times 10^{-9}$	measurement referenced to frequency observed $T_A=25^{\circ}\text{C}, V_{cc}$ varied from 3.135V to 3.465V, and $O_{Load}=15\text{ pF}$.
	Frequency Tolerance vs. Load	-5		+5	$\times 10^{-9}$	5% load change measurement referenced to frequency observed with $T_A=25^{\circ}\text{C}, V_{cc}=3.3V, O_{Load}=15\text{ pF}$.
	Short-Term Stability Allan Variance			0.05	$\times 10^{-9}$	Temperature stability, no EMI/EMC or other interference, test after power for 1 hour ref. to $25^{\circ}\text{C}; 1\text{ s}$.
	G-Sensitivity			1	$\times 10^{-9}/\text{g}$	
	Aging Tolerance Per Day	-3		+3	$\times 10^{-9}$	$T_A=25^{\circ}\text{C}, V_{cc}=3.3V$, and after 30 days of operation.
	Aging Tolerance 1 Year	-0.3		+0.3	$\times 10^{-6}$	
Power	Steady Consumption			230	mA	@ 25°C
	Warm up current			600	mA	
	Supply Voltage	3.135	3.3	3.465	V	
	Warm up Time			5	min	@ 25°C within $\pm 0.1 \times 10^{-6}$ of final frequency with reference after 1 hour on.



Phase Noise	Phase Noise @25°C			-65	dBc/Hz	1Hz
				-100		10Hz
				-130		100Hz
				-150		1KHz
				-155		10KHz
				-155		100KHz
				-155		1MHz
Environmental Conditions	Operating Temperature	-40		+105	°C	
	Storage Temperature	-55		+105	°C	
	ESD Level	Human Body Model,class2: 2000V to 4000V; ANSI/ESDA/JEDEC JS-001-2010.				
		Machine Model, class B: 200V to 400V; JEDEC JESD22-A115C.				
	Moisture Sensitivity Level	Level 3.				
	Vibration	Test Condition: 0.75mm ;acceleration:10g;10Hz~2000Hz, one cycle per 30 min, test 2 hour. (3 times for each 3 directions X ,Y , Z) .IEC 68-2-06 Test Fc.				
Shock	100g; 6ms; half sine wave (3 times for each 3 directions X ,Y, Z),IEC 68-2-27 Test Ea/Severity 50A.					



2. Mechanical Structure(mm)

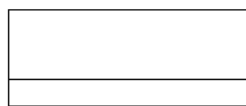
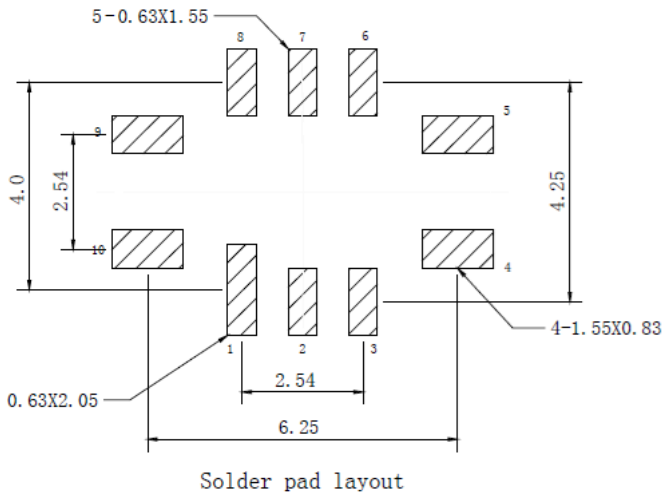

Right view

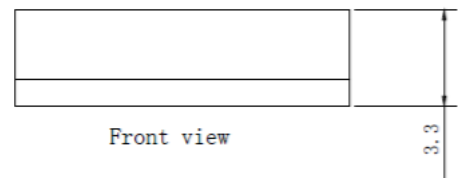
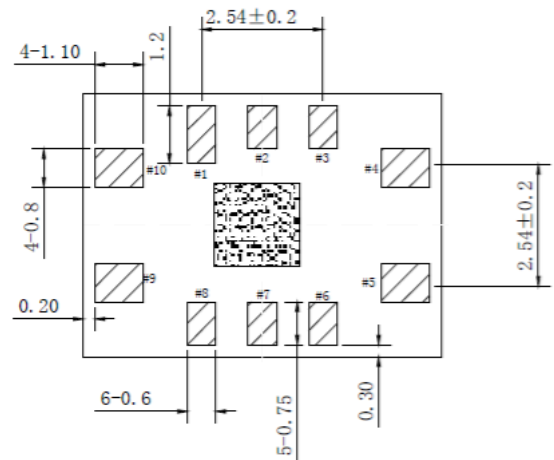

Front view

Pin Function

Pin	Function
1, 2, 3, 6, 7, 8	NC
4	GND
5	OUTPUT
9	VCC
10	NC

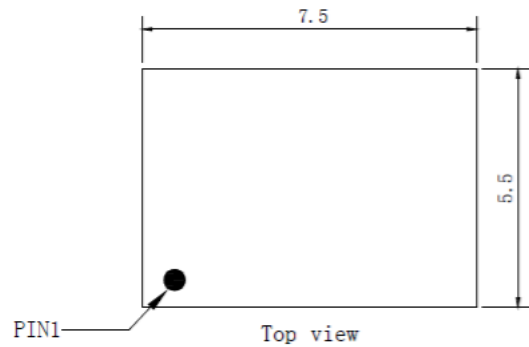

Note1: Tolerance $\pm 0.3\text{mm}$ without mark

Note2: Referential Weight 0.3g

Note3: NC is not connect



3. Test circuit

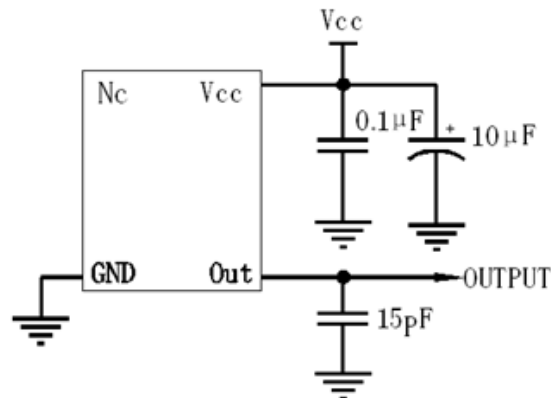

4. Reflow Soldering Curve (RoHS)

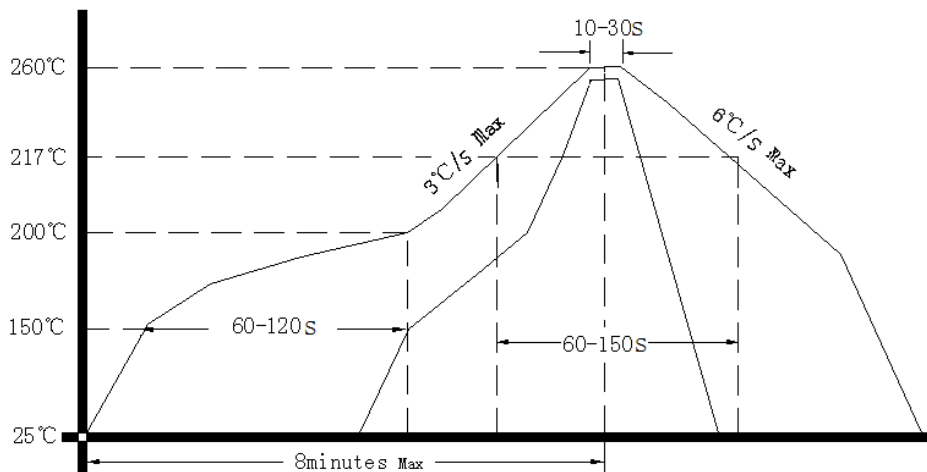

Note: Passing through reflow upside down is not supported

5. Package: Tape & Reel (mm)

