

Customer Code : _____

DATASHEET

DAPU P/N: 022S-G323-100.00MHz

Customer P/N: _____

DAPU			Customer Approval
Drew	Audited	Approved	Stamp, please! Thanks!
Date: 2024.06.12			

Guangdong Dapu Telecom Technology Co.,Ltd

Building 5, No.24, Industrial East Road, Songshanhu Park, Dongguan, Guangdong, P.R. China

TEL: 0086-0769-88010888 FAX: 0086-0769-81800098



1. Electrical Parameters

MODEL: O22S-G323-100.00MHz						
Item	Description	Parameters			Unit	Test Condition
		Min.	Typ.	Max.		
Output	Frequency	100.00			MHz	
	Output Waveform	HCMOS				
	Output Low Voltage			0.4	V	$V_{cc}=5V, O_{load}=15pF$
	Output High Voltage	4.5			V	$V_{cc}=5V, O_{load}=15pF$
	Duty Cycle	40		60	%	@50%
	Rise / Fall Time			2	ns	(20%~80%)
	Load	15			pF	
	Spurious			-80	dBc	
Frequency Stabilities	Frequency Tolerance vs. Operating Temperature Range	-0.02		+0.02	$\times 10^{-6}$	T_A varied from $-20^{\circ}C$ to $70^{\circ}C$, measurement referenced to frequency observed with $f_{ref}=(f_{max}+f_{min})/2, V_{cc}=5V, O_{load}=15pF$, temperature variable speed less than $2^{\circ}C$ per minute.
	Initial Frequency Tolerance	-0.3		+0.3	$\times 10^{-6}$	Measurement referenced to frequency observed with $T_A=25^{\circ}C, V_{cc}=5V, V_c=2V$, and after 15 minutes of operation, within 30 days after ex-works.
	Frequency Tolerance vs. Supply Voltage	-5		+5	$\times 10^{-9}$	measurement referenced to frequency observed $T_A=25^{\circ}C, V_{cc}$ varied from 4.75V to 5.25V, $V_c=2V$ and $O_{Load}=15pF$.
	Frequency Tolerance vs. Load	-5		+5	$\times 10^{-9}$	10% load change measurement referenced to frequency observed with $T_A=25^{\circ}C, V_{cc}=5V, V_c=2V$, and $O_{Load}=15pF$.
	G-Sensitivity			1	$\times 10^{-9}/g$	Worst axis
	Aging Tolerance Per Day	-3		+3	$\times 10^{-9}$	V_{cc}, V_c, T_A constant measurement referenced to frequency observed with $T_A=25^{\circ}C, V_{cc}=5V, V_c=2V$, and after 30 days of operation.
	Aging Tolerance 1 Year	-0.3		+0.3	$\times 10^{-6}$	
	Aging Tolerance 10 Years	-2		+2	$\times 10^{-6}$	
Power Supply	Supply Voltage	4.75	5	5.25	V	
	Reference Voltage	4.3	4.5	4.7	V	
	Steady Consumption			260	mA	@ $25^{\circ}C$
	Warm up current			600	mA	
	Warm-Up Time			3	minutes	@ $25^{\circ}C$ within $\pm 0.1 \times 10^{-6}$ of final Frequency with reference after 1 hour on.



Voltage Control Characteristics	Frequency Tuning Range			-2.5	$\times 10^{-6}$	$V_c=0V$. measurement referenced to $V_c=2V$
		-0.3		+0.3	$\times 10^{-6}$	$V_c=2V$. measurement referenced to exactly 100.00MHz
		+2.5			$\times 10^{-6}$	$V_c=4V$. measurement referenced to $V_c=2V$
	Linearity			10	%	
	Slope	Positive				
	Input Impedance	100				K Ω
Phase Noise	Phase Noise @25°C			-90	dBc/Hz	10Hz
				-125		100Hz
				-153		1KHz
				-165		10KHz
				-167		100KHz
				-167		1MHz
Environmental Conditions	Operable Temperature	-20		+70	°C	
	Storage Temperature	-55		+105	°C	
	ESD Level	Human Body Model, class2: 2000V to 4000V; ANSI/ESDA/JEDEC JS-001-2010.				
		Machine Model, class B: 200V to 400V; JEDEC JESD22-A115C.				
	Moisture Sensitivity Level	Level 2.				
	Vibration	Test Condition: 0.75mm ;acceleration:10g;5Hz~500Hz, one cycle per 30 min, test 2 hour. (3 times for each 3 directions X , Y , Z), IEC 68-2-06 Test Fc.				
	Shock	50g; 11ms; half sine wave (3 times for each 3 directions X, Y, Z), IEC 68-2-27 Test Ea/Severity 50A.				
Free fall	100 mm, The frequency difference between before and after the test is less than 2E-7					
Full Package Storage	Relative humidity (%)	20% ~70%				
	Temperature (°C)	-10~35°C				



2. Mechanical Structure (mm)

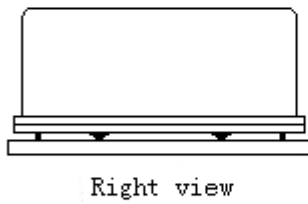
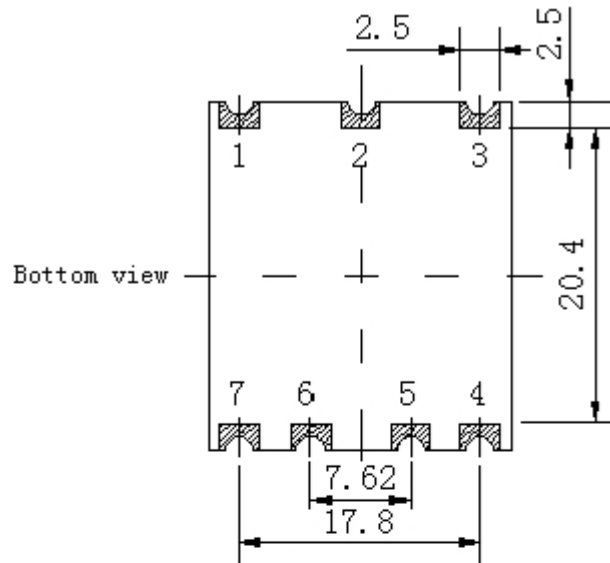
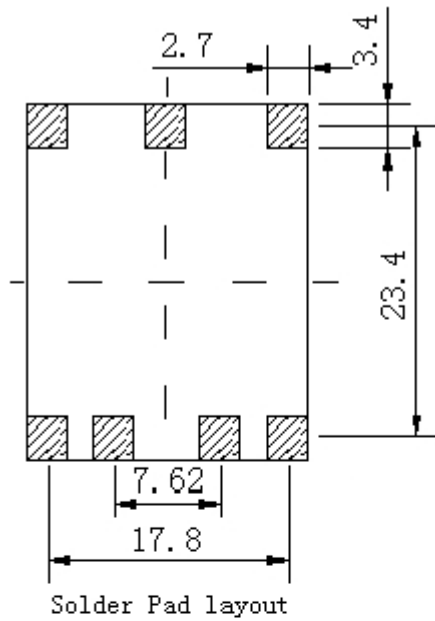

PIN FUNCTION

PIN	NOTATION	FUNCTION
1	VC	Control Voltage
2	VREF	Reference Voltage
3	VCC	Supply Voltage
4	OUTPUT	RF Output
5,6	NC	Not Connect
7	GND	GND

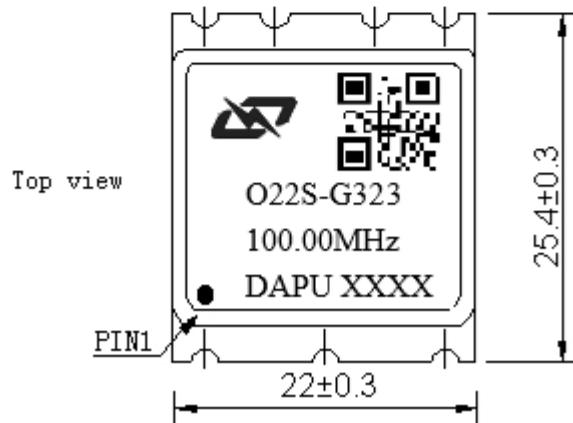

Note1: Tolerance $\pm 0.20\text{mm}$ without mark

Note2: The first two xx representative: year.
After two xx representative: week.

Note3: Referential weight 7.8g



3. Test Circuit

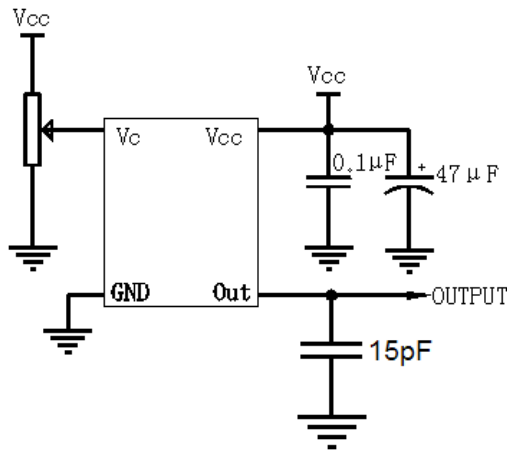

4. Reflow Soldering Curve (RoHS)

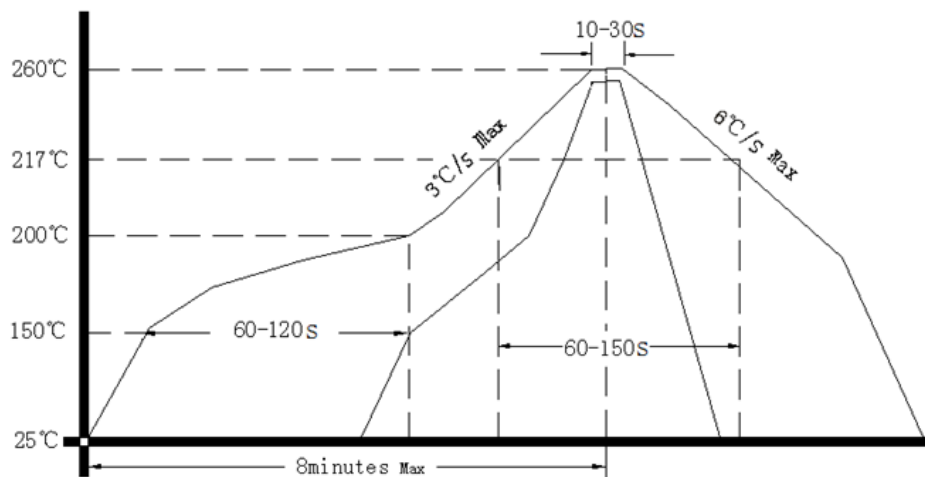

Note: Passing through reflow upside down is not supported

5. Package: Tape & Reel (mm)

